

15	GHL 200-15	28.0	30.6	13.0	31.6
14	GHL 200-14	26.0	28.6	13.0	29.6
13	GHL 200-13	24.0	26.6	13.0	27.6
12	GHL 200-12	22.0	24.6	13.0	25.6
11	GHL 200-11	20.0	22.6	13.0	23.6
10	GHL 200-10	18.0	20.6	13.0	21.6
09	GHL 200-09	16.0	18.6	11.0	19.6
08	GHL 200-08	14.0	16.6	9.0	17.6
07	GHL 200-07	12.0	14.6	7.0	15.6
06	GHL 200-06	10.0	12.6	5.0	13.6
05	GHL 200-05	8.0	10.6	5.0	11.6
04	GHL 200-04	6.0	8.6	4.0	9.6
03	GHL 200-03	4.0	8.0	-	7.6
02	GHL 200-02	2.0	6.0	-	5.6
POLES	PART NO.	A	B	C	D

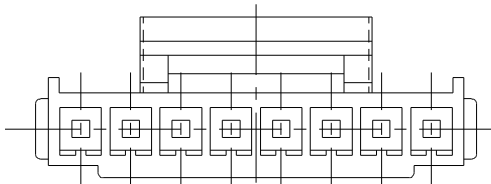
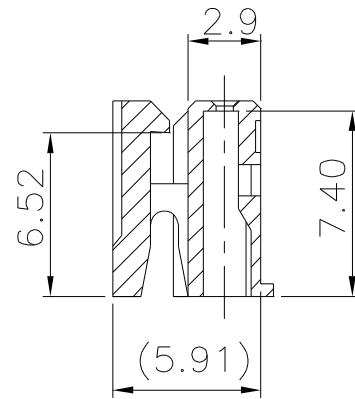
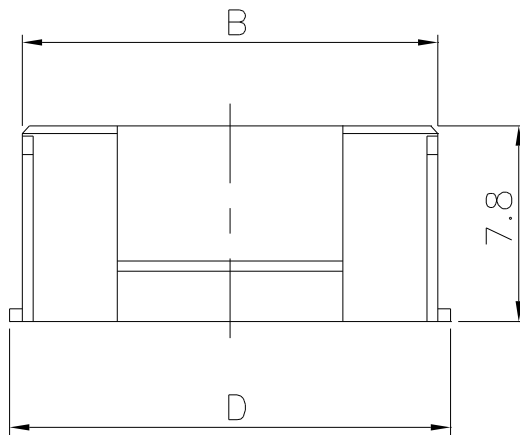
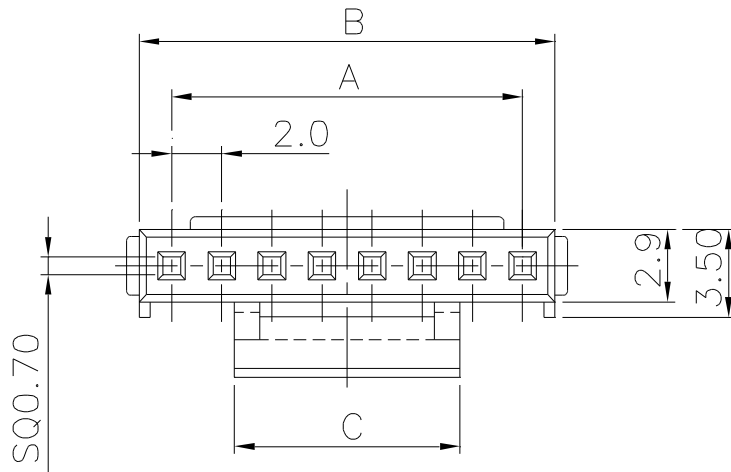

No.	DESCRIPTION	MATERIAL	Q'ty	TREATMENT	REMARKS
ITEM NAME		DRAW NAME		SCALE	
MODEL		DRAW No.		DATE	
DESIGNED	CHECKED	CHECKED	APPROVED	FILE No.	
				REF' DWG	