

THIS DRAWING CONTAINS CONFIDENTIAL INFORMATION PROPRIETARY TO GEO YOUNG. IT MUST NOT BE REPRODUCED OR DISCLOSED TO OTHERS OR USED IN ANY MANNER WITHOUT THE EXPRESS WRITTEN AUTHORIZATION OF GEO YOUNG.

REV No.	REVISION NOTE	DATE	DESIGN	CHECK	CHECK	APPROVE

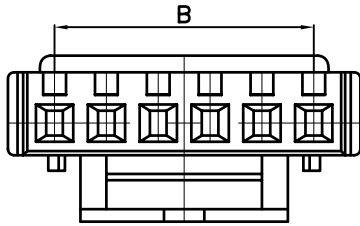

4P ~ 15P

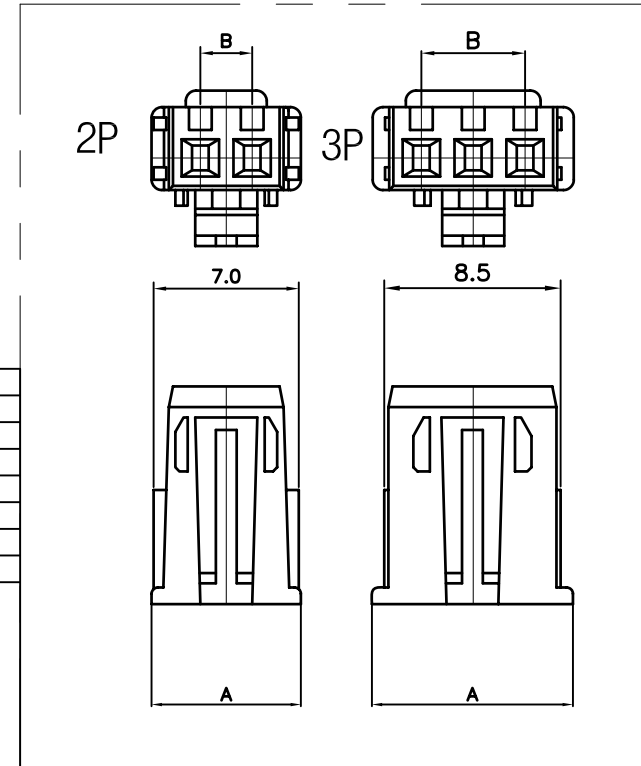
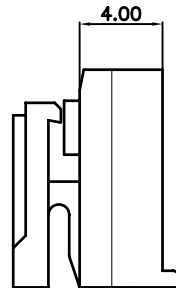
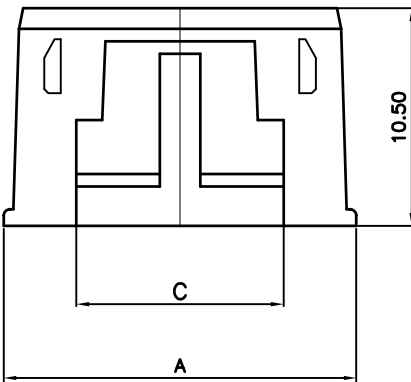

	A	B	C
GHL250-2P	7.20	2.50	1.35
GHL250-3P	9.70	5.0	1.35
GHL250-4P	12.2	7.50	2.75
GHL250-5P	14.7	10.0	2.75
GHL250-6P	17.0	12.5	10.0
GHL250-7P	19.5	15.0	12.5
GHL250-8P	22.0	17.5	15.0
GHL250-9P	24.5	20.0	17.5
GHL250-10P	27.0	22.5	
GHL250-11P	29.5	25.0	
GHL250-12P	32.0	27.5	
GHL250-13P	34.5	30.0	
GHL250-14P	37.0	32.5	
GHL250-15P	39.5	35.0	

1	MOLD	NY66	UL94-V0				
1 ~ 4	±0.1	No.	DESCRIPTION	MATERIAL	Q'ty	TREATMENT	REMARKS
4 ~ 16	±0.2	GHL250-02P-15P		DRAW NAME	GHL250-02P-15P	SCALE	1 / 1
16 ~ 63	±0.3	MODEL		DRAW No.	WAF02-197	DATE	06.03.09
63 ~ 250	±0.5	DESIGNED	CHECKED	CHECKED	APPROVED	FILE No.	FIT-WAF02-197
250 ~ 1000	±0.8	GENERAL TOLERANCE	박환기			REF' DWG	
1000 ~ 2000	±1.2						