

**GT 200 (CRIMP TERMINAL)**

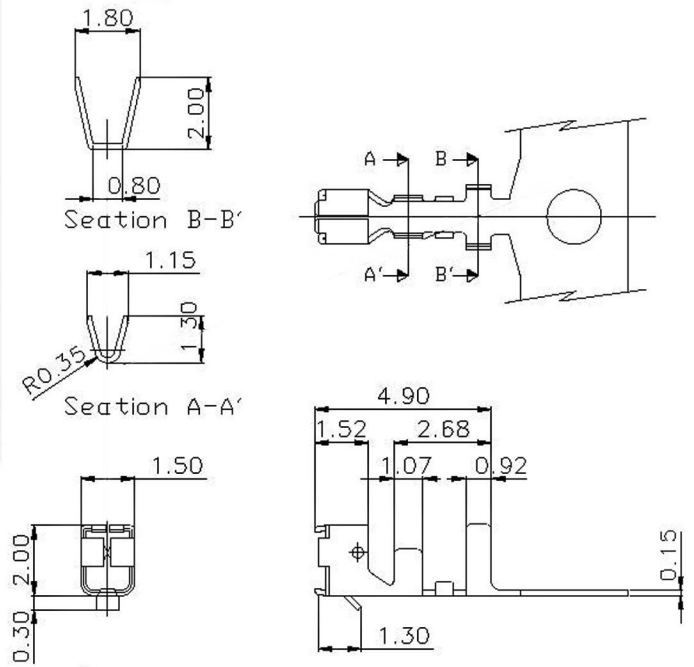

(mm)

PART NO.	MATERIAL	WIRE SIZE	INSULATION O.D	SUPPLY
GT 200	Tin plated P-B	AWG#24 ~ AWG#28	Φ1.5mm Max	15,000EA/Roll

No.	DESCRIPTION	MATERIAL	Q'ty	TREATMENT	REMARKs
ITEM NAME		DRAW NAME		SCALE	1 / 1
MODEL		DRAW No.		DATE	
DESIGNED	CHECKED	CHECKED	APPROVED	FILE No.	<b>GY GEO YOUNG</b>
				REF* DWG	