

REV No.	REVISION NOTE	DATE	DESIGNED	CHECKED	CHECKED	APPROVED
△						

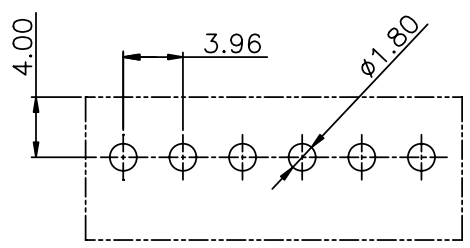
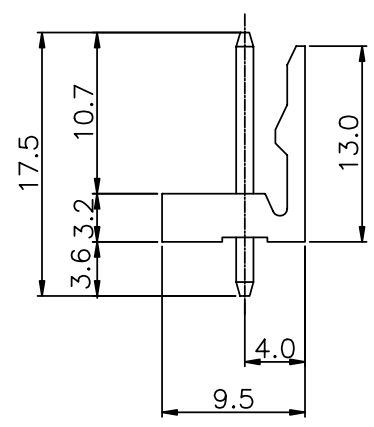
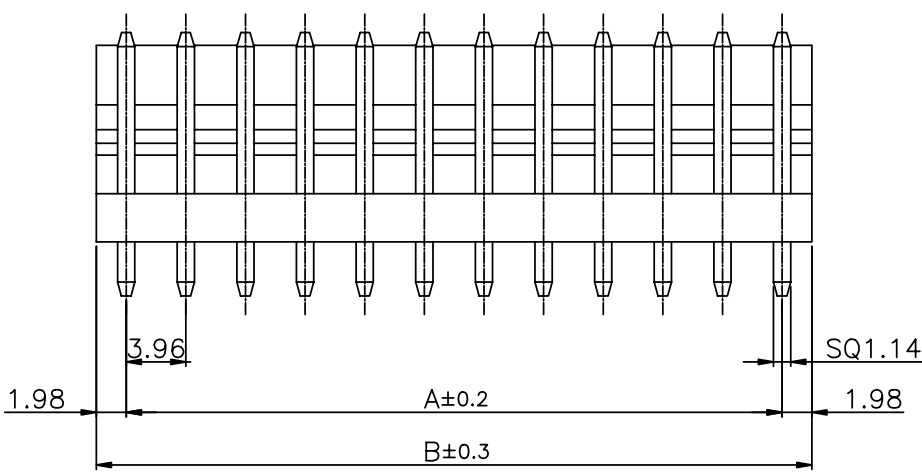
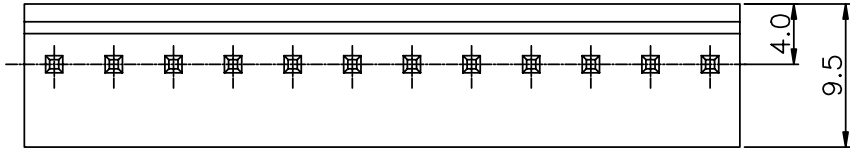

P.C.B LAY OUT

PART NO.	A	B
LPH03-02	3.96	7.92
LPH03-03	7.92	11.88
LPH03-04	11.88	15.84
LPH03-05	15.84	19.80
LPH03-06	19.80	23.76
LPH03-07	23.76	27.72
LPH03-08	27.72	31.68
LPH03-09	31.68	35.64
LPH03-10	35.64	39.60
LPH03-11	39.60	43.56
LPH03-12	43.56	47.52

	PIN(1.14*17.5)	BRASS		Cu2~3um, Sn3~5um	
	WAFER	NY66-UL94V2(101L)			
No.	DESCRIPTION	MATERIAL	Q'ty	TREATMENT	REMARKs
ITEM NAME	LPH03-(02P~12P)	DWG NAME	LPH03-(02P~12P)	SCALE	1 / 1
MODEL	WAFER(3.96mm)	DWG No.	STD01-015-2	DATE	2012.02.10
DESIGNED	CHECKED	CHECKED	APPROVED	FILE No.	FIT-STD01-015-2
				REF' DWG	



THIS DRAWING CONTAINS CONFIDENTIAL INFORMATION PROPRIETARY TO GEO YOUNG. IT MUST NOT BE REPRODUCED OR DISCLOSED TO OTHERS OR USED IN ANY OTHER WAY IN WHOLE OR PART EXCEPT AS AUTHORIZED IN WRITING BY GEO YOUNG.