

REV No.	REVISION NOTE	DATE	DESIGNED	CHECKED	APPROVED
▲					

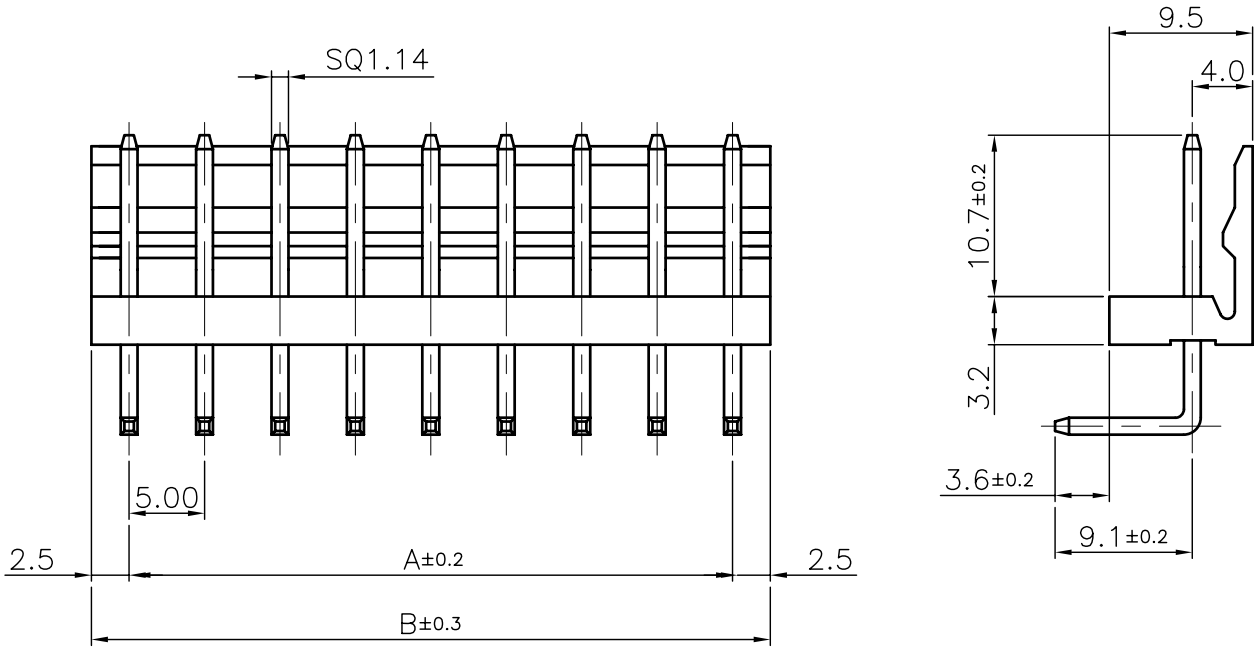

USER SPEC	PART No.	A	B	비 고
	LPHA05 - 02P	5.0	10.0	
	LPHA05 - 03P	10.0	15.0	
	LPHA05 - 04P	15.0	20.0	
	LPHA05 - 05P	20.0	25.0	
	LPHA05 - 06P	25.0	30.0	
	LPHA05 - 07P	30.0	35.0	
	LPHA05 - 08P	35.0	40.0	
	LPHA05 - 09P	40.0	45.0	

2	PIN(1.14*27.5)	BRASS(SN)		동(CU)하지 2~3Um 석(SN) 3~5Um ±0.1Um광택 도금	
1	WAFER	NY66, 101L, A <sub>3</sub> K		원색	
No.	DESCRIPTION	MATERIAL	Q'ty	TREATMENT	REMARKS
ITEM NAME	LPHA05	DWG NAME	LPHA05	SCALE	1 / 1
MODEL	PIN HEADER	DWG No.	STD01-027	DATE	2000.12.18
DESIGNED	CHECKED	CHECKED	APPROVED	FILE No.	FIT-STD01-027
				수 주 처	



THIS DRAWING CONTAINS CONFIDENTIAL INFORMATION PROPRIETARY TO GEO YOUNG. IT MUST NOT BE REPRODUCED OR DISCLOSED TO OTHERS OR USED IN ANY OTHER WAY IN WHOLE OR PART EXCEPT AS AUTHORIZED IN WRITING BY GEO YOUNG.