

REV No.	REVISION NOTE	DATE	DESIGNED	CHECKED	CHECKED	APPROVED
△						

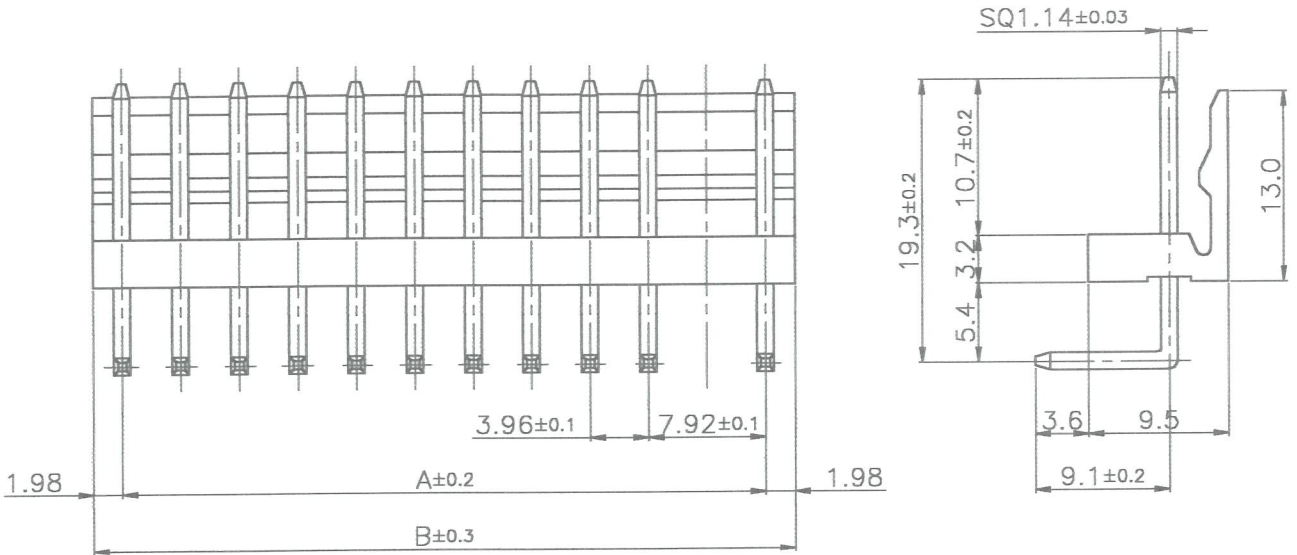

THIS DRAWING CONTAINS CONFIDENTIAL INFORMATION PROPRIETARY TO GEO YOUNG. IT MUST NOT BE REPRODUCED OR DISCLOSED TO OTHERS OR USED IN ANY OTHER WAY IN WHOLE OR PART EXCEPT AS AUTHORIZED IN WRITING BY GEO YOUNG.

USER SPEC.	ITEM NO.	A	B
	LPHAP03-02	7.92	11.88
	LPHAP03-03	11.88	15.84
	LPHAP03-04	15.84	19.80
	LPHAP03-05	19.80	23.76
	LPHAP03-06	23.76	27.72

USER SPEC.	ITEM NO.	A	B
	LPHAP03-07	27.72	31.68
	LPHAP03-08	31.68	35.64
	LPHAP03-09	35.64	39.60
	LPHAP03-10	39.60	43.56
	LPHAP03-11	43.56	47.52



	PIN(1.14*27.5)	BRASS		Cu2~3um, Sn3~5um	
	WAFER	NY66, 101L, A3K			
No.	DESCRIPTION	MATERIAL	Q'ty	TREATMENT	REMARKS
ITEM NAME	LPHAP03-02P~11P	DWG NAME	LPHAP03-02P~11P	SCALE	1 / 1
MODEL	STANDARD	DWG No.	STD01-018	DATE	2000.12.21
DESIGNED	CHECKED	CHECKED	APPROVED	FILE No.	FIT-STD01-018
				REF' DWG	

GEO YOUNG