

REV No.	REVISION NOTE	DATE	DESIGNED	CHECKED	APPROVED
▲					

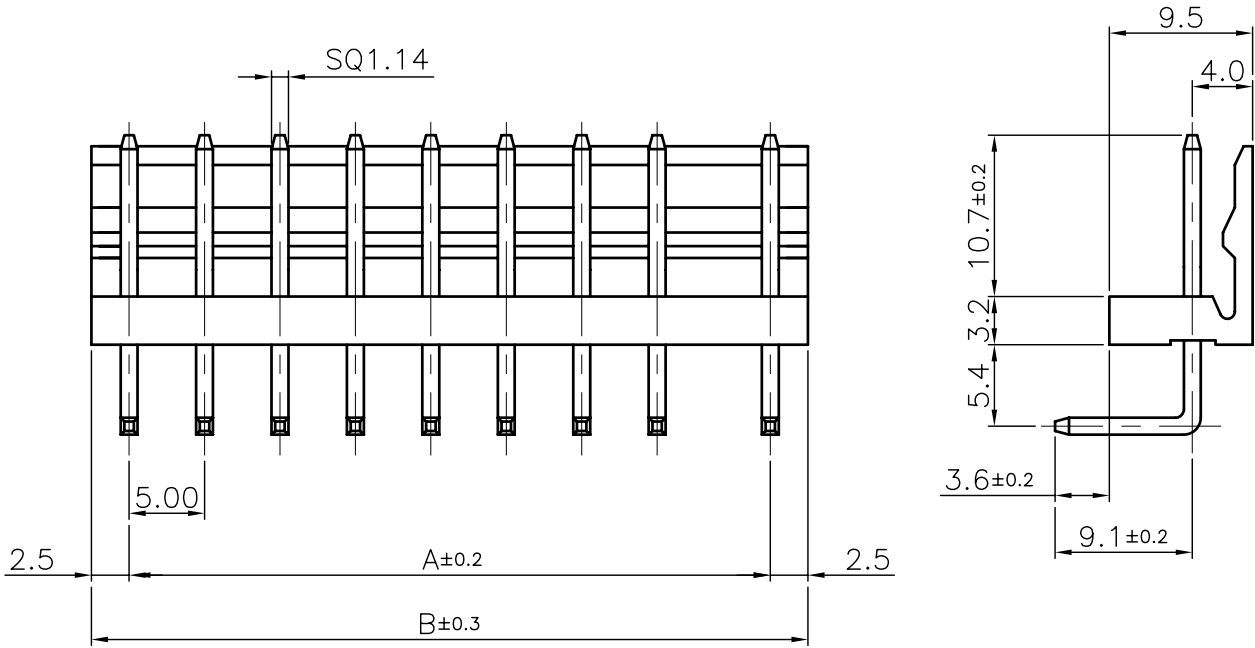

USER SPEC	PART No.	A	B	비 고
	LPHAP05 - 02P	7.5	12.5	
	LPHAP05 - 03P	12.5	17.5	
	LPHAP05 - 04P	17.5	22.5	
	LPHAP05 - 05P	22.5	27.5	
	LPHAP05 - 06P	27.5	32.5	
	LPHAP05 - 07P	32.5	37.5	
	LPHAP05 - 08P	37.5	42.5	
	LPHAP05 - 09P	42.5	47.5	

2	PIN(1.14*27.5)	BRASS(SN)		동(CU)하지 2~3Um 석(SN) 3~5Um ±0.1Um광택 도금	
1	WAFER	NY66, 101L, A ₃ K		원색	
No.	DESCRIPTION	MATERIAL	Q'ty	TREATMENT	REMARKs
ITEM NAME	LPHAP05	DWG NAME	LPHAP05	SCALE	1 / 1
MODEL	PIN HEADER	DWG No.	STD01-028	DATE	2000.12.18
DESIGNED	CHECKED	CHECKED	APPROVED	FILE No.	FIT-STD01-028
				수 주 처	



THIS DRAWING CONTAINS CONFIDENTIAL INFORMATION PROPRIETARY TO GEO YOUNG. IT MUST NOT BE REPRODUCED OR DISCLOSED TO OTHERS OR USED IN ANY OTHER WAY IN WHOLE OR PART EXCEPT AS AUTHORIZED IN WRITING BY GEO YOUNG.