

REV No.	REVISION NOTE	DATE	DESIGNED	CHECKED	APPROVED
---------	---------------	------	----------	---------	----------

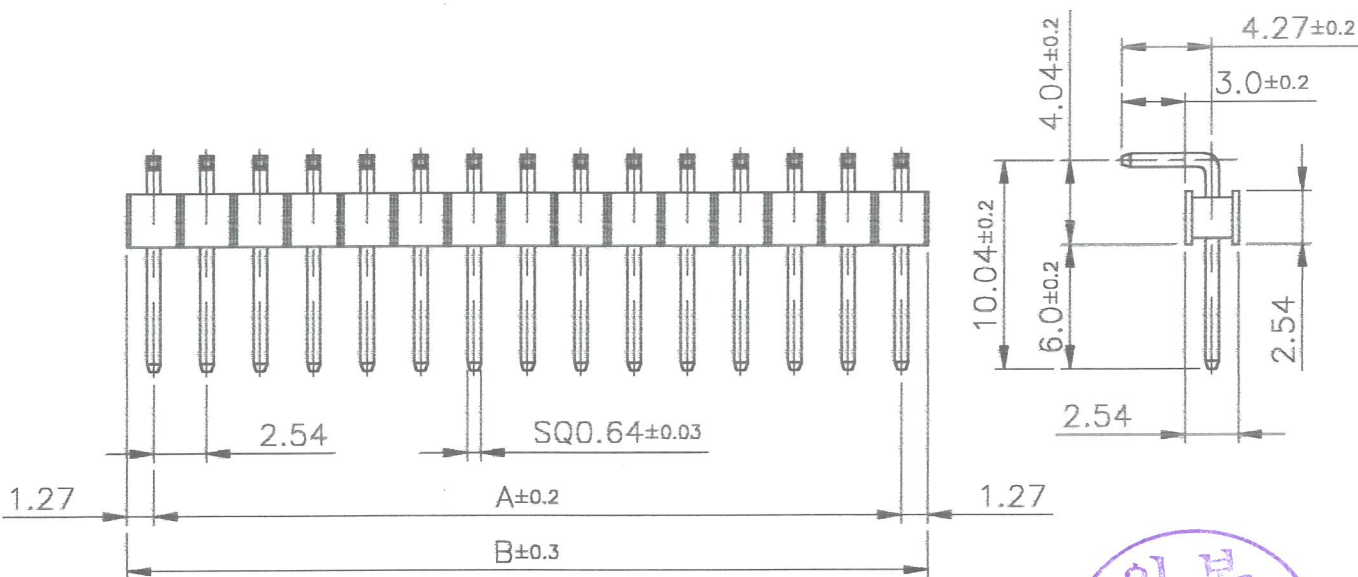

	A	B		A	B		A	B
2P	2.54	5.08	12P	27.94	30.48	22P	53.34	55.88
3P	5.08	7.62	13P	30.48	33.02	23P	55.88	58.42
4P	7.62	10.16	14P	33.02	35.52	24P	58.42	60.96
5P	10.16	12.70	15P	35.52	38.10	25P	60.96	63.50
6P	12.70	15.24	16P	38.10	40.64	26P	63.50	66.04
7P	15.24	17.78	17P	40.64	43.18	27P	66.04	68.58
8P	17.78	20.32	18P	43.18	45.72	28P	68.58	71.12
9P	20.32	22.86	19P	45.72	48.26	29P	71.12	73.66
10P	22.86	25.40	20P	48.26	50.80	30P	73.66	76.20
11P	25.40	27.94	21P	50.80	53.34			

2	PIN(0.64*14.2)	BRASS	SN : 동(CU)하지 2~3Um 석(SN) 3~5Um ± 0.1Um광택 도금 Sn Pb :동(CU)하지 1~2Um , Sn+Pb 3~5Um (Sn90%+Pb10%) Au : NI하지 1~2Um , Au (FLASH 0.05Um)		
1	WAFER(PH03-30P)	Nylon66	BLACK		
No.	DESCRIPTION	MATERIAL	Q'ty	TREATMENT	REMARKs
ITEM NAME	PHA03 -142- (N)	DWG NAME	PHA03 -142- (N)	SCALE	1 / 1
MODEL	PIN HEADER	DWG No.	PH0301-007	DATE	2001.01.02
DESIGNED	CHECKED	CHECKED	APPROVED	FILE No.	
<i>[Signature]</i>		<i>[Signature]</i>	<i>[Signature]</i>	수주처	

QS-051-002(1) A4, A3

THIS DRAWING CONTAINS CONFIDENTIAL INFORMATION PROPRIETARY TO GEO YOUNG. IT MUST NOT BE REPRODUCED OR DISCLOSED TO OTHERS OR USED IN ANY OTHER WAY IN WHOLE OR PART EXCEPT AS AUTHORIZED IN WRITING BY GEO YOUNG.